

DEVICE PERFORMANCE SPECIFICATION

Revision 4.2 MTD/PS-0207

January 15, 2009

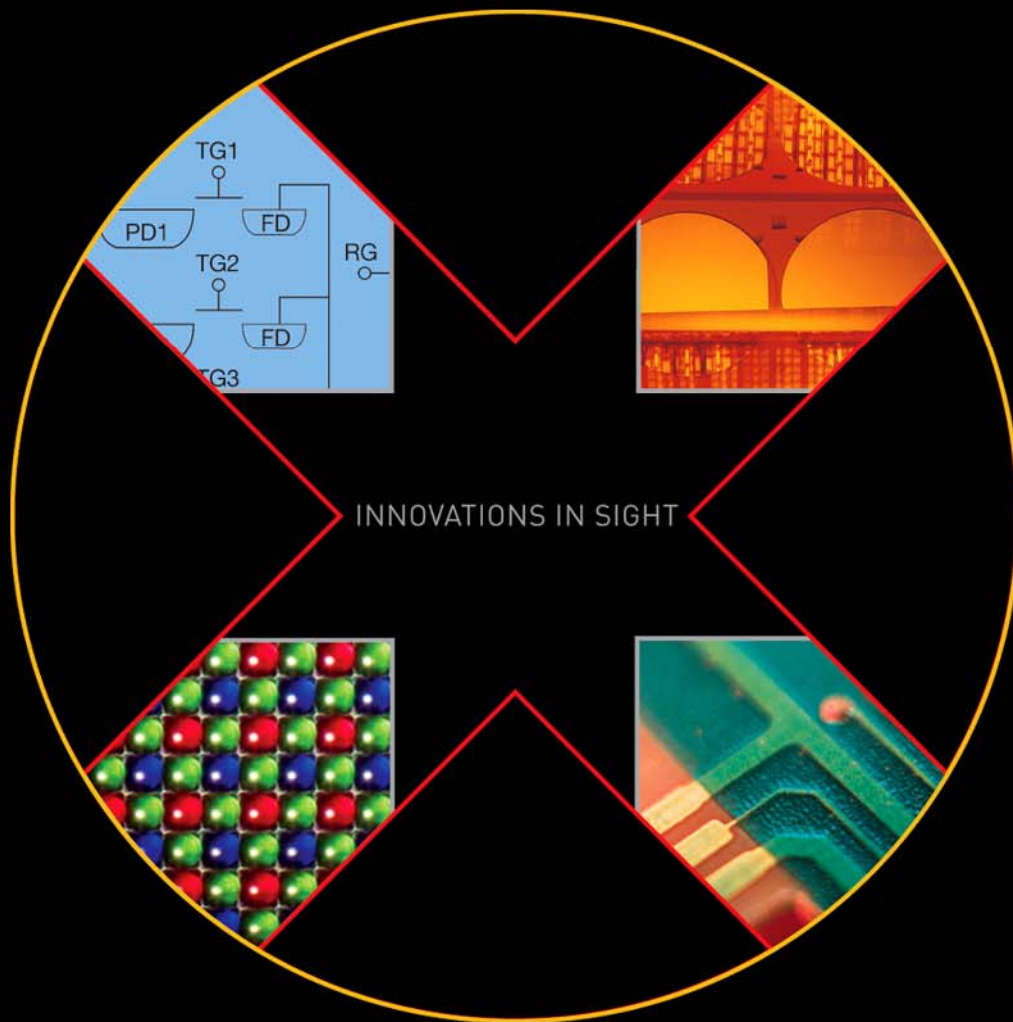

KODAK KAF-6303E IMAGE SENSOR

3072 (H) X 2048 (V) FULL-FRAME CCD IMAGE SENSOR

TABLE OF CONTENTS

Summary Specification 4
 Description 4
 Features..... 4
 Application 4
Ordering Information 5
Device Description 6
 Architecture 6
 Dark Reference Pixels..... 7
 Output Structure..... 7
 Dummy Pixels..... 7
 Image Acquisition 7
 Charge Transport 7
 Horizontal Register 8
 Output Structure..... 8
 Physical Description..... 9
 Pin Description and Device Orientation..... 9
Imaging Performance 11
 Typical Operational Conditions 11
 Specifications 11
Typical Performance Curves..... 13
Defect Definitions..... 14
 Operating Conditions..... 14
 Specifications 14
Operation..... 15
 Absolute Maximum Ratings..... 15
 DC Bias Operating Conditions 16
 AC Operating Conditions..... 16
 Clock Levels..... 16
Timing..... 17
 Requirements and Characteristics 17
 Frame Timing 18
 Line Timing (each Output)..... 19
Storage and Handling 20
 Storage Conditions 20
 ESD 20
 Cover Glass Care and Cleanliness 20
 Environmental Exposure..... 20
 Soldering Recommendations 20
Mechanical Information 21
 Completed Assembly 21
Quality Assurance And Reliability 23
 Quality Strategy 23
 Replacement 23
 Liability of the Supplier 23
 Liability of the Customer..... 23
 Reliability 23
 Test Data Retention..... 23
 Mechanical..... 23

Warning: Life Support Applications Policy..... 23
Revision Changes..... 24

TABLE OF FIGURES

Figure 1: Block Diagram..... 6
Figure 2: Output Structure Load Diagram 8
Figure 3: Pinout Diagram 9
Figure 4: Typical Spectral Response..... 13
Figure 5: Frame Timing 18
Figure 6: Line Timing 19
Figure 7: Timing Diagrams 19
Figure 8: Completed Assembly (1 of 2) 21
Figure 9: Completed Assembly (2 of 2) 22

SUMMARY SPECIFICATION

KODAK KAF-6303E IMAGE SENSOR

3072 (H) X 2048 (V) FULL FRAME CCD IMAGE SENSOR

DESCRIPTION

The KAF-6303E is a high performance monochrome area CCD (charge-coupled device) image sensor with 3072H x 2048V photo active pixels designed for a wide range of image sensing applications in the 0.3 nm to 1.0 nm wavelength band. Typical applications include military, scientific, and industrial imaging. A 74dB dynamic range is possible operating at room temperature.

The sensor is built with a true two-phase CCD technology. This technology simplifies the support circuits that drive the sensor and reduces the dark current without compromising charge capacity. The transparent gate results in spectral response increased ten times at 400nm, compared to a front side illuminated standard polysilicon gate technology. The sensitivity is increased 50% over the rest of the visible wavelengths. Total chip size is 29.0 mm x 19.1 mm and is housed in a 26-pin, 0.88" wide DIL ceramic package with 0.1" pin spacing.

FEATURES

- 6M Pixel Area CCD
- 3072H x 2048V (9 μm) Pixels
- Transparent Gate True Two Phase Technology (Enhanced Spectral Response)
- 2-Phase Register Clocking
- 100% Fill Factor
- Low Dark Current (<10pA/cm² at 25° C)

APPLICATION

- Medical Imaging
- Scientific Imaging

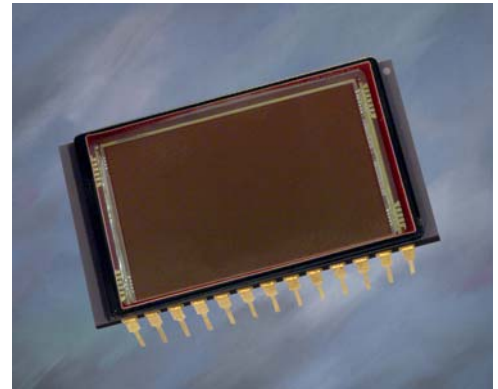

Parameter	Typical Value
Architecture	Full Frame CCD
Total Number of Pixels	3088(H) x 2056(V)]
Number of Active Pixels	3072 (H) x 2048 (V) = approx. 1.6 M
Pixel Size	9 μm (H) x 9 μm (V)
Active Image Size	27.65 mm (H) x 18.48 mm (V)
Chip Size	29.0 mm (H) x 19.1 mm (V)
Saturation Signal	100,000 electrons
Output Sensitivity	10 μV/electron
Quantum Efficiency (450, 550, 650 nm)	40%, 52%, 65%
Readout Noise (10 MHz)	15 electrons rms
Dark Current (T = 25° C, Accumulation Mode)	<10pA/cm ²
Dark Current Doubling Rate	6°C
Dynamic Range [Saturation Signal/Dark Noise]	76 dB
Maximum Data Rate	10 MHz
Package	CERDIP Package (sidebrazed)
Cover Glass	Clear or AR coated, 2 sides

ORDERING INFORMATION

Catalog Number	Product Name	Description	Marking Code
4H0703	KAF- 6303-AAA-CD-B2	Monochrome, No Microlens, CERDIP Package (sidebrazed), Clear Cover Glass with AR coating (both sides), Grade 2	KAF-6303-AAA [Serial Number]
4H0704	KAF- 6303-AAA-CD-AE	Monochrome, No Microlens, CERDIP Package (sidebrazed), Clear Cover Glass with AR coating (both sides), Engineering Sample	
4H0481	KAF- 6303-AAA-CP-B2	Monochrome, No Microlens, CERDIP Package (sidebrazed), Taped Clear Cover Glass, no coatings, Grade 2	
2H4478	KAF- 6303-AAA-CP-AE	Monochrome, No Microlens, CERDIP Package (sidebrazed), Taped Clear Cover Glass, no coatings, Engineering Sample	
4H0079	KEK-4H0079-KAF-6303-12-5	Evaluation Board (Complete Kit)	N/A

Please see ISS Application Note "Product Naming Convention" (MTD/PS-0892) for a full description of naming convention used for KODAK image sensors.

For all reference documentation, please visit our Web Site at www.kodak.com/go/imagers.

Address all inquiries and purchase orders to:

Image Sensor Solutions
Eastman Kodak Company
Rochester, New York 14650-2010

Phone: (585) 722-4385
Fax: (585) 477-4947
E-mail: imagers@kodak.com

Kodak reserves the right to change any information contained herein without notice. All information furnished by Kodak is believed to be accurate.

DEVICE DESCRIPTION

ARCHITECTURE

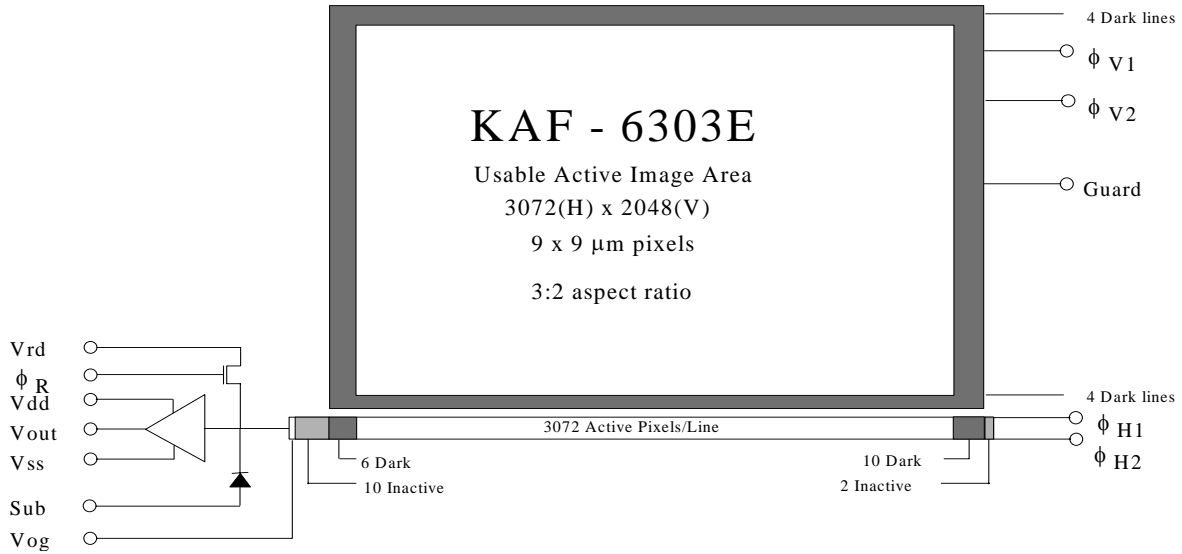

Figure 1: Block Diagram

The sensor consists of 3088 parallel (vertical) CCD shift registers each 2056 elements long. These registers act as both the photosensitive elements and as the transport circuits that allow the image to be sequentially read out of the sensor. The elements of these registers are arranged into a 3072 x 2048 photosensitive array surrounded by a light shielded dark reference of 16 columns and 8 rows. The parallel (vertical) CCD registers transfer the image one line at a time into a single 3100 element (horizontal) CCD shift register. The horizontal register transfers the charge to a single output amplifier. The output amplifier is a two-stage source follower that converts the photo-generated charge to a voltage for each pixel

Dark Reference Pixels

Surrounding the peripheral of the device is a border of light shielded pixels. This includes 6 leading and 10 trailing pixels on every line excluding dummy pixels. There are also 4 full dark lines at the start of every frame and 4 full dark lines at the end of each frame. Under normal circumstances, these pixels do not respond to light. However, dark reference pixels in close proximity to an active pixel, or the outer bounds of the chip (including the first two lines out), can scavenge signal depending on light intensity and wavelength and therefore will not represent the true dark signal.

Output Structure

Charge presented to the floating diffusion (FD) is converted into a voltage and current amplified in order to drive off-chip loads. The resulting voltage change seen at the output is linearly related to the amount of charge placed on FD. Once the signal has been sampled by the system electronics, the reset gate (\bar{R}) is clocked to remove the signal and FD is reset to the potential applied by V_{rd} . More signal at the floating diffusion reduces the voltage seen at the output pin. In order to activate the output structure, an off-chip load must be added to the V_{out} pin of the device – see Figure 2.

Dummy Pixels

Within the horizontal shift register are 10 leading and 2 trailing additional shift phases that are not associated with a column of pixels from the vertical register. These pixels contain only horizontal shift register dark current signal and do not respond to light. A few leading dummy pixels may scavenge false signal depending on operating conditions.

IMAGE ACQUISITION

An electronic representation of an image is formed when incident photons falling on the sensor plane create electron-hole pairs within the sensor. These photon-induced electrons are collected locally by the formation of potential wells at each photogate or pixel site. The number of electrons collected is linearly dependent on light level and exposure time and non-linearly dependent on wavelength. When the pixel's capacity is reached, excess electrons will leak into the adjacent pixels within the same column. This is termed blooming. During the integration period, the ϕ_{V1} and ϕ_{V2} register clocks are held at a constant (low) level. See Figure 7- Timing Diagrams.

CHARGE TRANSPORT

Referring again to Figure 7- Timing Diagrams, the integrated charge from each photogate is transported to the output using a two step process. Each line (row) of charge is first transported from the vertical CCD's to the horizontal CCD register using the ϕ_{V1} and ϕ_{V2} register clocks. The horizontal CCD is presented a new line on the falling edge of ϕ_{V2} while ϕ_{H1} is held high. The horizontal CCD's then transport each line, pixel by pixel, to the output structure by alternately clocking the ϕ_{H1} and ϕ_{H2} pins in a complementary fashion. On each falling edge of ϕ_{H2} a new charge packet is transferred onto a floating diffusion and sensed by the output amplifier.

HORIZONTAL REGISTER

Output Structure

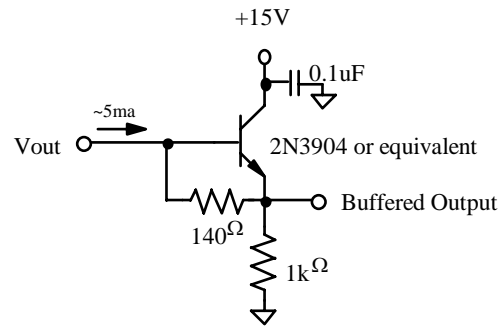

Figure 2: Output Structure Load Diagram

PHYSICAL DESCRIPTION

Pin Description and Device Orientation

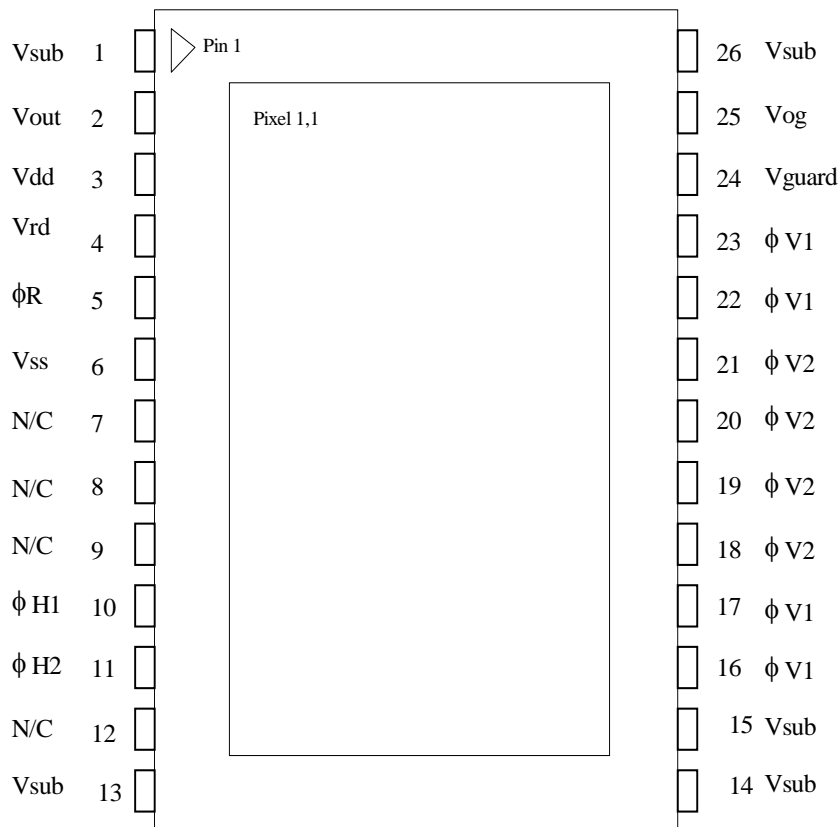

Figure 3: Pinout Diagram

Note: The KAF-1603E is mechanically the same and electrically identical to the KAF-0402E sensor. It is also mechanically the same as the KAF-0261E and KAF-3200E sensors. There are some electrical differences since the KAF-0261E has two outputs and two additional clock inputs. The KAF-3200E requires that pin 11 be a “No connect” and be electrically floating. Refer to their specifications for details.

Pin	Name	Description
1	Vsub	Substrate (Ground)
2	Vout	Video Output
3	Vdd	Amplifier Supply
4	Vrd	Reset Drain
5	ϕR	Reset Clock
6	Vss	Amplifier Supply Return
7	N/C	No Connection (open pin)
8	N/C	No Connection (open pin)
9	N/C	No Connection (open pin)
10	$\phi H1$	Horizontal CCD Clock - Phase 1
11	$\phi H2$	Horizontal CCD Clock - Phase 2
12	N/C	No Connection (open pin)
13	Vsub	Substrate (Ground)

Pin	Name	Description
14	Vsub	Substrate (Ground)
15	Vsub	Substrate (Ground)
16	$\phi V1$	Vertical CCD Clock - Phase 1
17	$\phi V1$	Vertical CCD Clock - Phase 1
18	$\phi V2$	Vertical CCD Clock - Phase 2
19	$\phi V2$	Vertical CCD Clock - Phase 2
20	$\phi V2$	Vertical CCD Clock - Phase 2
21	$\phi V2$	Vertical CCD Clock - Phase 2
22	$\phi V1$	Vertical CCD Clock - Phase 1
23	$\phi V1$	Vertical CCD Clock - Phase 1
24	Vguard	Guard Ring
25	Vog	Output Gate
26	Vsub	Substrate (Ground)

IMAGING PERFORMANCE

TYPICAL OPERATIONAL CONDITIONS

All values measured at 25°C, and nominal operating conditions. These parameters exclude defective pixels.

SPECIFICATIONS

Description	Symbol	Min.	Nom.	Max	Units	Notes	Verification Plan
Saturation Signal Vertical CCD capacity Horizontal CCD capacity Output Node capacity	Nsat	85000 170000 190000	100000 200000 220000	120000 240000 240000	electrons / pixel	1	design ¹¹
Red Quantum Efficiency Green Quantum Efficiency Blue Quantum Efficiency	Rr Rg Rb	52 42 30	65 52 40	75 62 48	%QE		design ¹¹
Photoresponse Non-Linearity	PRNL		1.0	2.0	%	2	design ¹¹
Photoresponse Non-Uniformity	PRNU		1.0	3.0	%	3	die ¹⁰
Dark Signal	Jdark		15 3.5	50 10	electrons / pixel / sec pA/cm ²	4	die ¹⁰
Dark Signal Doubling Temperature		5	6.3	7.5	oC		design ¹¹
Dark Signal Non-Uniformity	DSNU		10	50	electrons / pixel / sec	5	die ¹⁰
Dynamic Range	DR	70	74		dB	6	design ¹¹
Charge Transfer Efficiency	CTE	0.99997	0.99999				die ¹⁰
Output Amplifier DC Offset	Vodc	9.5	10.5	11.5	V	7	die ¹⁰
Output Amplifier Bandwidth	f-3dB		45		Mhz	8	design ¹¹
Output Amplifier Sensitivity	Vout/Ne~	9	10	11	uV/e~		design ¹¹
Output Amplifier output Impedance	Zout	175	200	2520	Ohms		design ¹¹
Noise Floor	ne~		15	20	electrons	9	die ¹⁰

Notes:

1. For pixel binning applications, electron capacity up to 330000 can be achieved with modified CCD inputs. Each sensor may have to be optimized individually for these applications. Some performance parameters may be compromised to achieve the largest signals.
2. Worst-case deviation from straight line fit, between 1% and 90% of V_{sat} .
3. One Sigma deviation of a 128x128 sample when CCD illuminated uniformly.
4. Average of all pixels with no illumination at 25°C
5. Average dark signal of any of 12 x 8 blocks within the sensor (each block is 128 x 128 pixels).
6. $20\log (N_{sat} / n_{e^-})$ at nominal operating frequency and 25°C.
7. Video level offset with respect to ground.
8. Last output amplifier stage only. Assumes 10pF off-chip load.
9. Output noise at 25°C, nominal operating frequency, and tint = 0.
10. A parameter that is measured on every sensor during production testing.
11. A parameter that is quantified during the design verification activity.

TYPICAL PERFORMANCE CURVES

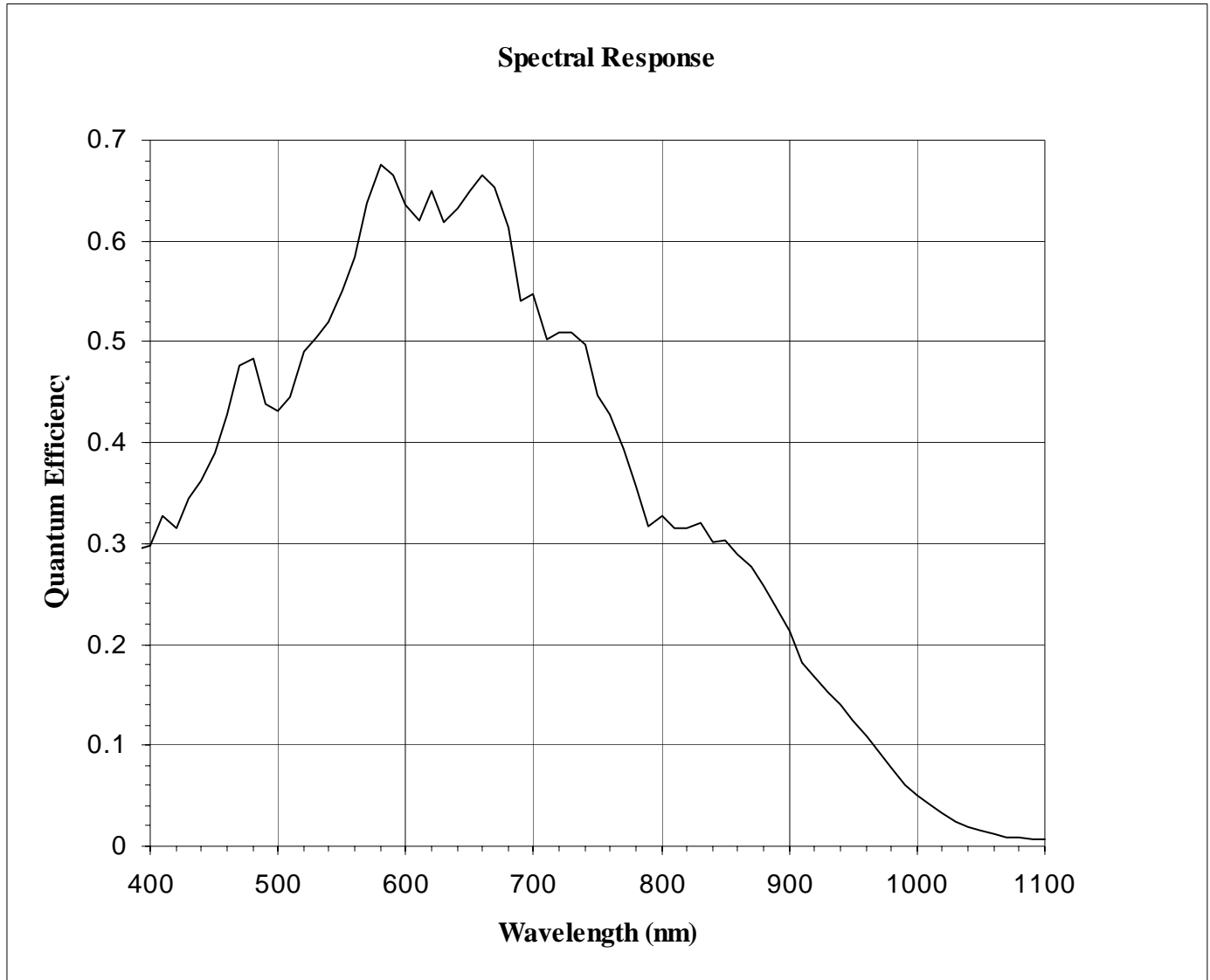

Figure 4: Typical Spectral Response

DEFECT DEFINITIONS

OPERATING CONDITIONS

All defect tests performed at T=25oC

SPECIFICATIONS

Classification	Point Defect		Cluster Defect		Maximum Cluster Size	Column Defect	
	Total	Zone A	Total	Zone A		Total	Zone A
C2	≤90	≤45	≤36	≤18	5	0	0

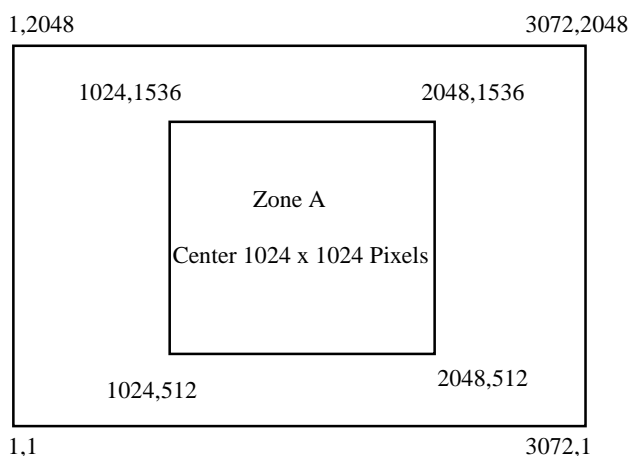

Point Defects

Dark: A pixel that deviates by more than 6% from neighboring pixels when illuminated to 70% of saturation

-- OR --

Bright: A pixel with a dark current greater than 10,000e/pixel/sec at 25C.

Cluster Defect

A grouping of not more than "Maximum Cluster Size" defects

Column Defect

A grouping of >5 contiguous point defects along a single column

A column containing a pixel with dark current > 30,000e/pixel/sec, OR A column that does not meet the CTE specification for all exposures less than the specified Max sat. signal level and greater than 2 Ke

A pixel which loses more than 250 e under 2Ke illumination

Neighboring Pixels

The surrounding 128 x 128 pixels or ± 64 column/rows

Defect Separation

Column and cluster defects are separated by no less than two (2) pixels in any direction (excluding single pixel defects)

Defect Region Exclusion

Defect region excludes the outer two (2) rows and columns at each side/end of the sensor.

OPERATION

ABSOLUTE MAXIMUM RATINGS

Description	Symbol	Minimum	Maximum	Units	Notes
Diode Pin Voltages	V_{diode}	0	20	V	1,2
Gate Pin Voltages - Type 1	V_{gate1}	-16	16	V	1,3
Gate Pin Voltages - Type 2	V_{gate2}	0	16	V	1,4
Inter-Gate Voltages	V_{g-g}		16	V	5
Output Bias Current	I_{out}		-10	mA	6
Output Load Capacitance	C_{load}		15	pF	6
Storage Temperature	T_{ST}	0	70	°C	
Humidity	RH	5	90	%	7

Notes:

1. Referenced to pin Vsub.
2. Includes pins: Vrd, Vdd, Vss, Vout, Vguard.
3. Includes pins: V1, V2, H1, H2.
4. Includes pins: R, Vog.
5. Voltage difference between overlapping gates. Includes: V1 to V2, H1 to H2, V2 to H1, H2 to Vog.
6. Avoid shorting output pins to ground or any low impedance source during operation.
7. T=25°C. Excessive humidity will degrade MTTF.

DC BIAS OPERATING CONDITIONS

Description	Symbol	Minimum	Nominal	Maximum	Units	Maximum DC Current (mA)	Notes
Reset Drain	Vrd	10.5	11.0	11.5	V	0.01	
Output Amplifier Return	Vss	1.5	2.0	2.5	V	0.45	
Output Amplifier Supply	Vdd	14.5	15	15.5	V	Iout	
Substrate	Vsub	0	0	0	V	0.01	
Output Gate	Vog	3.75	4.0	5.0	V	0.01	
Guard Ring	Vlg	8.0	10.0	12.0	V	0.01	
Video Output Current	Iout		-5	-10	mA	-	1

Note:

1. An output load sink must be applied to Vout to activate output amplifier – see Figure 2.

AC OPERATING CONDITIONS

Clock Levels

Description	Symbol	Level	Minimum	Nominal	Maximum	Units	Effective Capacitance
Vertical CCD Clock - Phase 1	$\phi V1$	Low	-10.5	-10.0	-9.5	V	82 nf (all $\phi V1$ pins)
Vertical CCD Clock - Phase 1	$\phi V1$	High	0.5	1.0	1.5	V	82 nf (all $\phi V1$ pins)
Vertical CCD Clock - Phase 2	$\phi V2$	Low	-10.5	-10.0	-9.5	V	820 nf (all $\phi V2$ pins)
Vertical CCD Clock - Phase 2	$\phi V2$	High	0.5	1.0	1.5	V	820 nf (all $\phi V2$ pins)
Horizontal CCD Clock - Phase 1	$\phi H1$	Low	-6.0	-3.0	-3.0	V	400pF
Horizontal CCD Clock - Phase 1	$\phi H1$	High	4.0	7.0	7.0	V	400pF
Horizontal CCD Clock - Phase 2	$\phi H2$	Low	-6.0	-3.0	-3.0	V	400pF
Horizontal CCD Clock - Phase 2	$\phi H2$	High	4.0	7.0	7.0	V	400pF
Reset Clock	ϕR	Low	-4.0	-3.0	-2.0	V	10pF
Reset Clock	ϕR	High	3.5	4.0	5.0	V	10pF

Notes:

1. All pins draw less than 10uA DC current.
2. Capacitance values relative to VSUB.

TIMING

REQUIREMENTS AND CHARACTERISTICS

Description	Symbol	Minimum	Nominal	Maximum	Units	Notes
ϕ H1, ϕ H2 Clock Frequency	f_H		4	15	MHz	1, 2, 3
ϕ V1, ϕ V2 Clock Frequency	F_V		25	50	kz	1, 2, 3
Pixel Period (I count)	t_e	67	250		ns	
ϕ H1, ϕ H2 Setup Time	$t_{\phi HS}$	0.5	1		μ s	
ϕ V1, ϕ V2 Clock Pulse Width	$t_{\phi V}$	10	20		μ s	2
Reset Clock Pulse Width	$t_{\phi R}$	10	20		ns	4
Readout Time	$t_{readout}$	531	1719		ms	5
Integration Time	t_{int}					6
Line Time	t_{line}	258.2	836		μ s	7

Notes:

1. 50% duty cycle values.
2. CTE may degrade above the nominal frequency.
3. Rise and fall times (10/90% levels) should be limited to 5-10% of clock period. Cross-over of register clocks should be between 40-60% of amplitude.
4. ϕ R should be clocked continuously.
5. $t_{readout} = (2056 t_{line})$
6. Integration time is user specified. Longer integration times will degrade noise performance.
7. $t_{line} = (3 * t_{\phi V}) + t_{\phi HS} + (3100) + t_e$.

FRAME TIMING

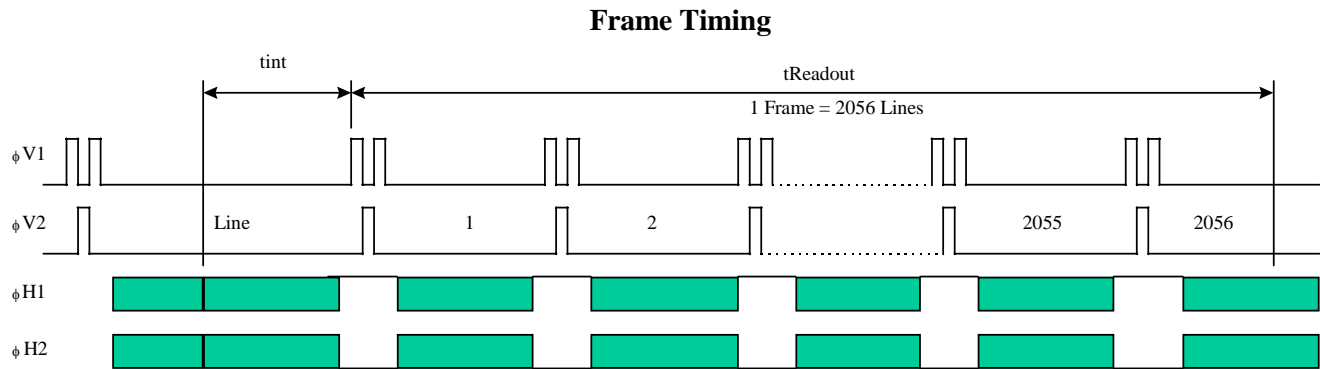

Figure 5: Frame Timing

LINE TIMING (EACH OUTPUT)

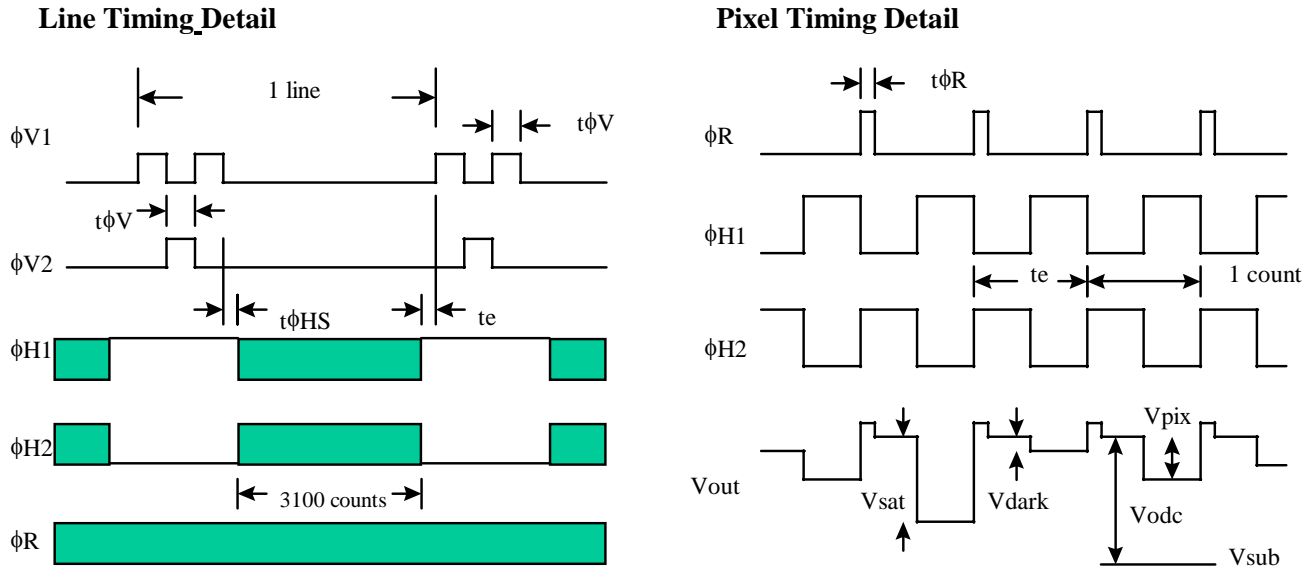
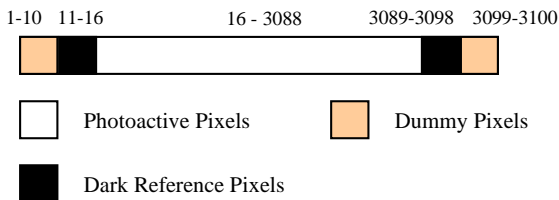

Figure 6: Line Timing

Line Content



- Vsat Saturated pixel video output signal
- Vdark Video output signal in no light situation, not zero due to Jdark
- Vpix Pixel video output signal level, more electrons = more negative
- Vodc Video level offset with respect to vsub
- Vsub Analog Ground

* See Image Acquisition section (page 4)

Figure 7: Timing Diagrams

STORAGE AND HANDLING

STORAGE CONDITIONS

Description	Symbol	Minimum	Maximum	Units	Notes
Storage Temperature	T _{ST}	0	70	°C	1
Operating Temperature	T _{OP}	-60	60	°C	

Notes:

- Storage toward the maximum temperature will accelerate color filter degradation.

ESD

- This device contains limited protection against Electrostatic Discharge (ESD). CCD image sensors can be damaged by electrostatic discharge. Failure to do so may alter device performance and reliability.
- Devices should be handled in accordance with strict ESD procedures for Class 0 (<250V per JESD22 Human Body Model test), or Class A (<200V JESD22 Machine Model test) devices. Devices are shipped in static-safe containers and should only be handled at static-safe workstations.
- See Application Note MTD/PS-1039 "Image Sensor Handling and Best Practices" for proper handling and grounding procedures. This application note also contains recommendations for workplace modifications for the minimization of electrostatic discharge.
- Store devices in containers made of electro-conductive materials.

COVER GLASS CARE AND CLEANLINESS

- The cover glass is highly susceptible to particles and other contamination. Perform all assembly operations in a clean environment.
- Touching the cover glass must be avoided.
- Improper cleaning of the cover glass may damage these devices. Refer to Application Note MTD/PS-1039 "Image Sensor Handling and Best Practices".

ENVIRONMENTAL EXPOSURE

- Do not expose to strong sun light for long periods of time. The color filters and/or microlenses may become discolored. Long time exposures to a static high contrast scene should be avoided. The image sensor may become discolored and localized changes in response may occur from color filter/microlens aging.
- Exposure to temperatures exceeding the absolute maximum levels should be avoided for storage and operation. Failure to do so may alter device performance and reliability.
- Avoid sudden temperature changes.
- Exposure to excessive humidity will affect device characteristics and should be avoided. Failure to do so may alter device performance and reliability.
- Avoid storage of the product in the presence of dust or corrosive agents or gases.

Long-term storage should be avoided. Deterioration of lead solderability may occur. It is advised that the solderability of the device leads be re-inspected after an extended period of storage, over one year.

SOLDERING RECOMMENDATIONS

- The soldering iron tip temperature is not to exceed 370°C. Failure to do so may alter device performance and reliability.
- Flow soldering method is not recommended. Solder dipping can cause damage to the glass and harm the imaging capability of the device. Recommended method is by partial heating. Kodak recommends the use of a grounded 30W soldering iron. Heat each pin for less than 2 seconds duration.

MECHANICAL INFORMATION

COMPLETED ASSEMBLY

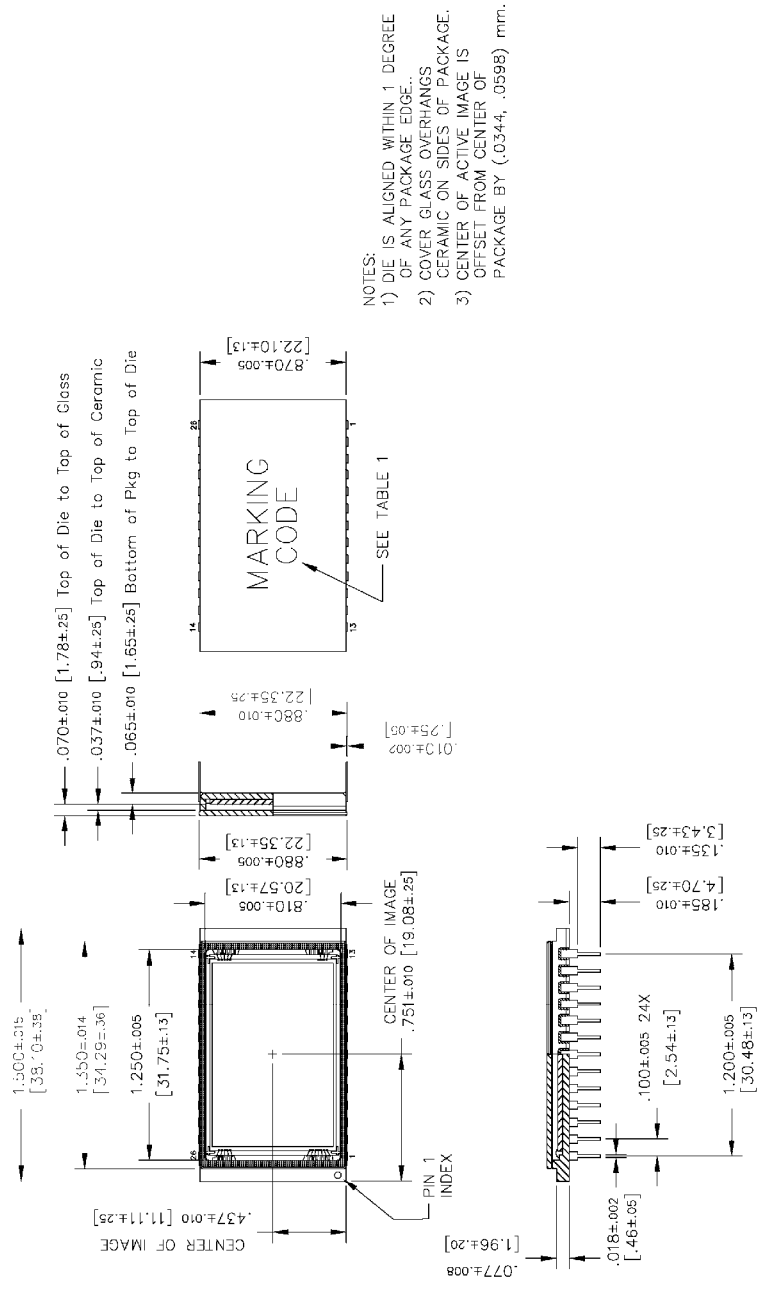

Figure 8: Completed Assembly (1 of 2)

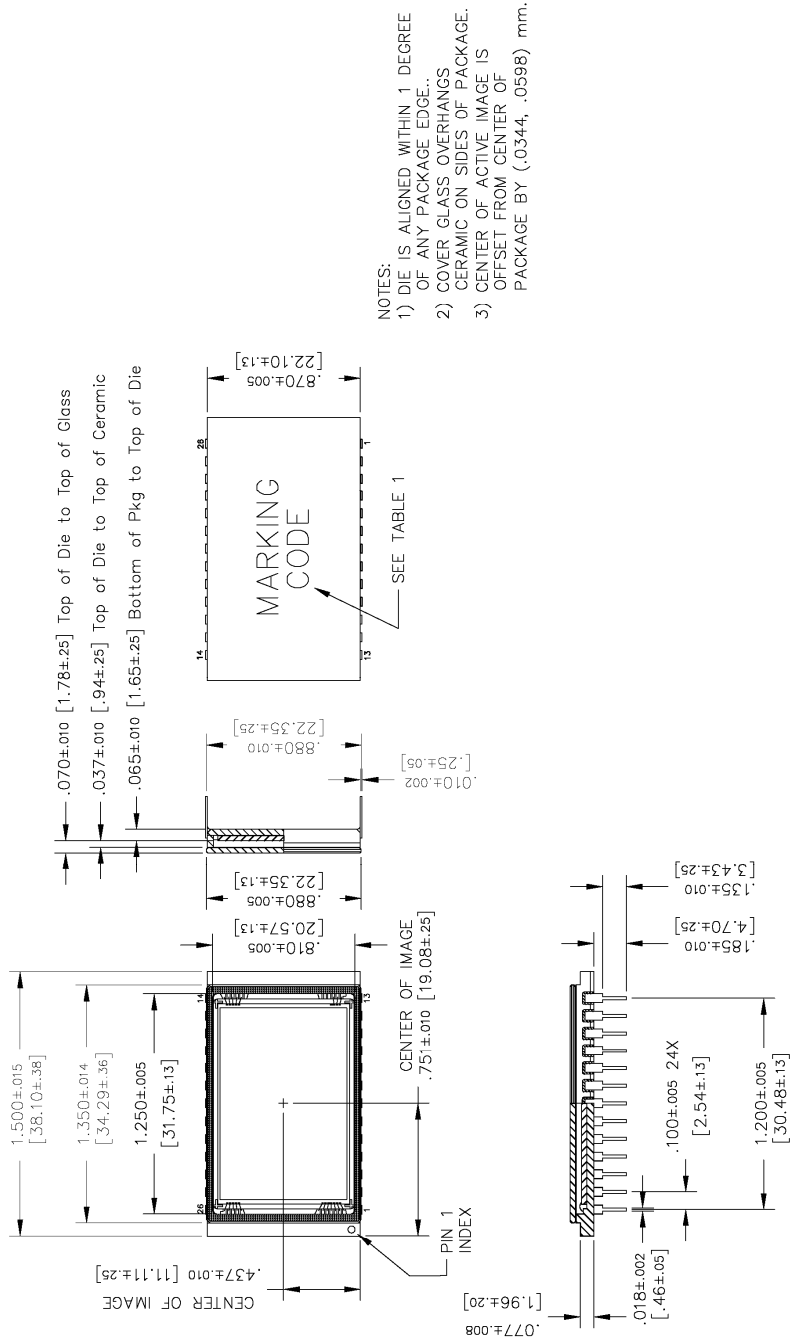

Figure 9: Completed Assembly [2 of 2]

QUALITY ASSURANCE AND RELIABILITY

QUALITY STRATEGY

All image sensors will conform to the specifications stated in this document. This will be accomplished through a combination of statistical process control and inspection at key points of the production process. Typical specification limits are not guaranteed but provided as a design target. For further information refer to ISS Application Note MTD/PS-0292, Quality and Reliability.

REPLACEMENT

All devices are warranted against failure in accordance with the terms of Terms of Sale. This does not include failure due to mechanical and electrical causes defined as the liability of the customer below.

LIABILITY OF THE SUPPLIER

A reject is defined as an image sensor that does not meet all of the specifications in this document upon receipt by the customer.

LIABILITY OF THE CUSTOMER

Damage from mechanical (scratches or breakage), electrostatic discharge (ESD) damage, or other electrical misuse of the device beyond the stated absolute maximum ratings, which occurred after receipt of the sensor by the customer, shall be the responsibility of the customer.

RELIABILITY

Information concerning the quality assurance and reliability testing procedures and results are available from the Image Sensor Solutions and can be supplied upon request. For further information refer to ISS Application Note MTD/PS-0292, Quality and Reliability.

TEST DATA RETENTION

Image sensors shall have an identifying number traceable to a test data file. Test data shall be kept for a period of 2 years after date of delivery.

MECHANICAL

The device assembly drawing is provided as a reference. The device will conform to the published package tolerances.

Kodak reserves the right to change any information contained herein without notice. All information furnished by Kodak is believed to be accurate.

WARNING: LIFE SUPPORT APPLICATIONS POLICY

Kodak image sensors are not authorized for and should not be used within Life Support Systems without the specific written consent of the Eastman Kodak Company. Product warranty is limited to replacement of defective components and does not cover injury or property or other consequential damages.

REVISION CHANGES

Revision Number	Description of Changes
1.0	Initial Release.
	Revised class 1 cosmetic specification. Removed UV enhanced device. Resubmitted for Cluster correction and definition.
2.0	Section 4.3 Cosmetic Specification: Remove Class 3, Revise Class 2 as follows: Point Defects: Total 90, Zone A 45 Clusters: Total 36, Zone A 18 Columns Total 0 Section 5.,1 Quality and Reliability, updated.
3.0	Section 3.3 AC Operating Conditions: Change Horizontal CCD Clock voltages for Phase 1 and Phase 2 as follow: Low Nominal from -4.0 to -3.0V Low Max. from -3.5 to -3.0V High Nominal from 6.0 to 7.0V High Max. from 6.5 to 7.0V Resubmission change: Corrected V1, V2 Clock Capacitance form 820 to 82nF. Updated ESD Caution.
4.0	Updated format. Removed part numbers per ECO 1051
4.1	Replaced photo of KAF-6303 device
4.2	Removed Class 1 parts from the defect specification table

This page intentionally left blank.

This page intentionally left blank.

This page intentionally left blank.

